

GS-1513A
GS-1530A
GS-1613A
GS-1630A

Resolution: 10 μ m

Resolution: 10 μ m

Resolution: 1 μ m

Resolution: 1 μ m

Instruction Manual

ONO SOKKI

This manual describes operations, maintenance, specifications, and notes on handling of the Linear Gauge Sensors GS-1513A/1530A (hereinafter called GS-1500A Series) and GS-1613A/1630A (hereinafter called GS-1600A Series). Before use of the GS-1500A Series and GS-1600A Series, be sure to read this manual. The notes described in this manual include the 'items which can cause damage to your property.' Be sure to handle these products following the instructions described in this manual. This manual also contains a warranty. Please keep this manual in a safe place.

CAUTION This symbol is used to indicate precautions where there is a risk of some personal injury to the operator or only material damage to the product if the product is handled incorrectly.

Overview and Features

The GS-1500A and GS-1600A Series Linear Gauge Sensors are detectors which use the linear scaling method for the displacement conversion mechanism and directly convert the displacement of a spindle to an electric signal.

When connected to the Ono Sokki digital gauge counter (DG-4000 Series), dimensions can be measured with high precision.

● **Features**

- Automation of measurement with attachment of an optional air lifter
- IP64's environment-proof performance is highly resistant to dust and water
- Durable body design achieves 5 million sliding counts (in our endurance testing)
- Applicable to all types of Ono Sokki gauge counters

CAUTION Notes on Usage



- The GS-1500A and GS-1600A Series Linear Gauge Sensors are precision equipment. Do not drop or give excessive vibration or impact.
- Do not disassemble the GS-1500A or GS-1600A Series Linear Gauge Sensors as it will cause dust or dirt to enter inside the sensors resulting in a fault. IP64 is not guaranteed in such a case.
- Do not pull the GS-1500A or GS-1600A Series cables with a force of 20N (2 kgf) or more.
- Do not suddenly release the spindle of a GS-1500A or GS-1600A Series Linear Gauge Sensor which has been pushed inside. Do not make any measurements in such a manner. It will distort the sensor precision and damage the internal mechanism.
When a measurement method with spindle release is necessary, always observe the allowable range of 1 mm or less from the measured object.
- Do not give a transverse force to the spindle of the GS-1500A or GS-1600A Series Linear Gauge Sensor. Do not tighten the stem with excessive force. Doing so will adversely affect the spindle operation and reduce the sensor lifetime.
- Do not fix the GS-1500A or GS-1600A Series Linear Gauge Sensor by directly applying screws to the stem portion.
- When replacing the probe of the GS-1500A or GS-1600A Series Linear Gauge Sensor, use great care to protect the spindle from torsional force greater than 0.3Nm.
- Do not use the GS-1500A or GS-1600A Series Linear Gauge Sensor in a location with corrosive or flammable gases.
- When using an air lifter (option), secure the Sensor with the mounting hole. In this case, however, if you hold its stem to mount the Sensor, it cannot be secured correctly or firmly. The protection measures equivalent to IP64 are not applied to the air lifter.
- Protection measures equivalent to IP64 have been applied to the GS-1500A and GS-1600A Series Linear Gauge Sensor. However, be sure to protect the Sensor using a cover not to get water directly. Avoid using the Sensor in a location which is exposed to direct jet.

Measurement Method

Use the following procedure to make measurements with the GS-1500A or GS-1600A Series Linear Gauge Sensor:

- (1) Connect the GS-1500A or GS-1600A Series Linear Gauge Sensor to the gauge counter.
- (2) Hold the probe portion by hand, carefully move the spindle, and measure the target (lower the spindle after approaching to within 1 mm from the measurement target).



- The spindle stopper inside the sensor is made of rubber, therefore, it cannot be used as the reference point. Use the position where the spindle is pushed in 0.2 mm or more.
- Never remove the dust-proof rubber cover which protects the spindle. If it should be damaged, immediately contact your sales representative or our sales office to order a new replacement.

Output Connector Pin Arrangement and Output Circuit

The following diagrams show the connector pin arrangement and output circuit of the GS-1500A and GS-1600A Series Linear Sensors, and the phase relationship of the output signals SIG1 and SIG2 in the spindle operation.

A single pitch of the output signal corresponds to 40 μ m for the GS-1500A Series and 4 μ m for the GS-1600A Series, respectively.

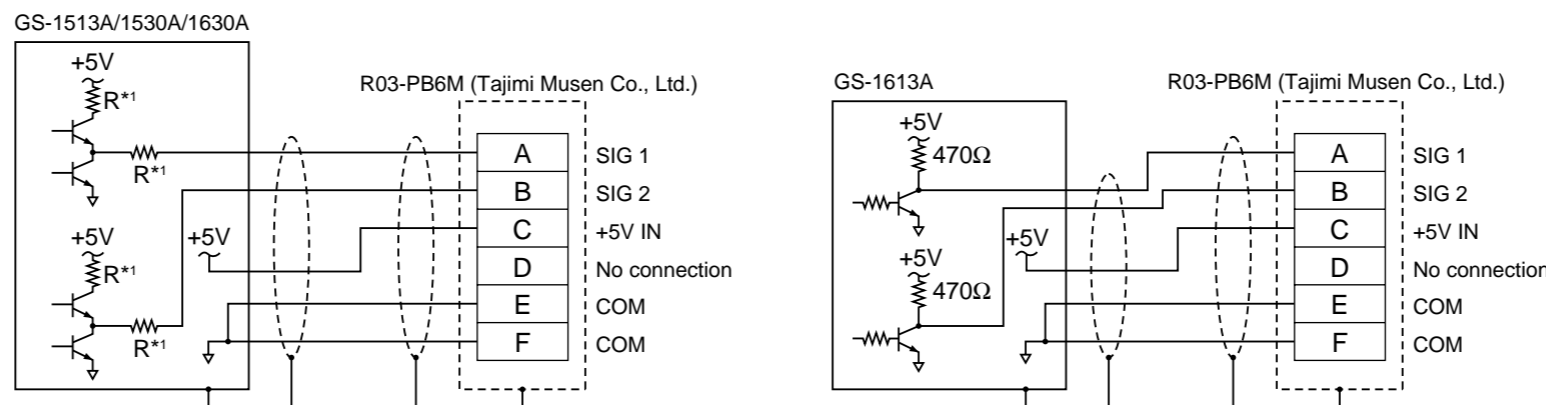

*1: GS-1500A Series: 68 Ω , GS-1630A: 220 Ω P = 40 μ m or 4 μ m



Probe exchange method

When replacing the probe of the GS-1500A or GS-1600A Series Linear Gauge Sensor, use great care to protect the spindle from torsional force greater than 0.3Nm.

- (1) Please stop an axis using an attached spanner so that twist power is not added. Please do not touch dust-proof rubber cover at this time.
- (2) The probe is transferred and removed with a finger. Please roll cloth, when you use a tool. A crack is not attached to the probe.

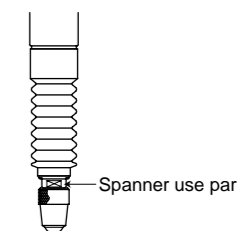

■ **Warranty**

1. This product is covered by a warranty for a period of one year from the date of purchase.
2. This warranty covers free-of-charge repair for defects judged to be the responsibility of the manufacturer, i.e., defects occurred while the product is used under normal operating conditions according to descriptions in this manual and notices on the unit label.
3. For free-of-charge repair, contact either your sales representative or our sales office nearby.
4. The following failures will be handled on a fee basis even during the warranty period.
 - (a) Failures occurring through misuse, mis-operation, or modification
 - (b) Failures occurring through mishandling (dropping) or transportation
 - (c) Failures occurring through natural calamities (fires, earthquakes, flooding, and lightning), environmental disruption, or abnormal voltage.

* For repairs after the warranty period expired, contact your sales representative or our sales office nearby.

ONO SOKKI WORLDWIDE

1-16-1, Hakusan, Midori-ku, Yokohama, 226-8507, Japan
 Phone : +81-45-935-3976
 Fax : +81-45-930-1906
 E-mail : overseas@onosokki.co.jp

Copyright © ONO SOKKI CO., Ltd. 2005 All rights reserved.
 B00001773 / IM02040101(5) 05X(MS)XXX

Mounting on the Retainer

Refer to the drawings below to mount the GS-1500A or GS-1600A Series Linear Sensor on the retainer so that the direction of motion of the spindle matches the length direction (displacement) of the object to be measured.

[Fix by holding the stem]

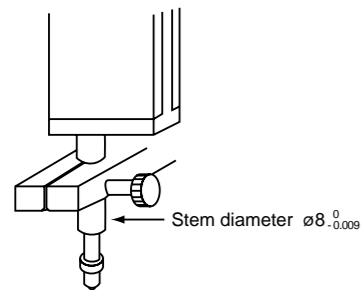

[Fix using the mounting holes]

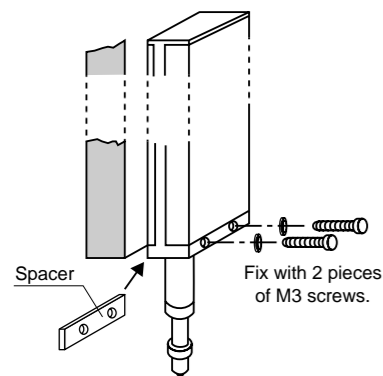

When the delivered one is replaced with the old type, use the spacer which is provided as an accessory.

When the sensor is properly mounted, a gap of about 0.5 mm will be provided between the top section of the sensor and the mounting face. Be sure to avoid fixing the sensor by forcibly eliminating this gap by holding the other fitting.

Dimensional Outline Drawing

● GS-1513A/1613A Dimensional Outline Drawing

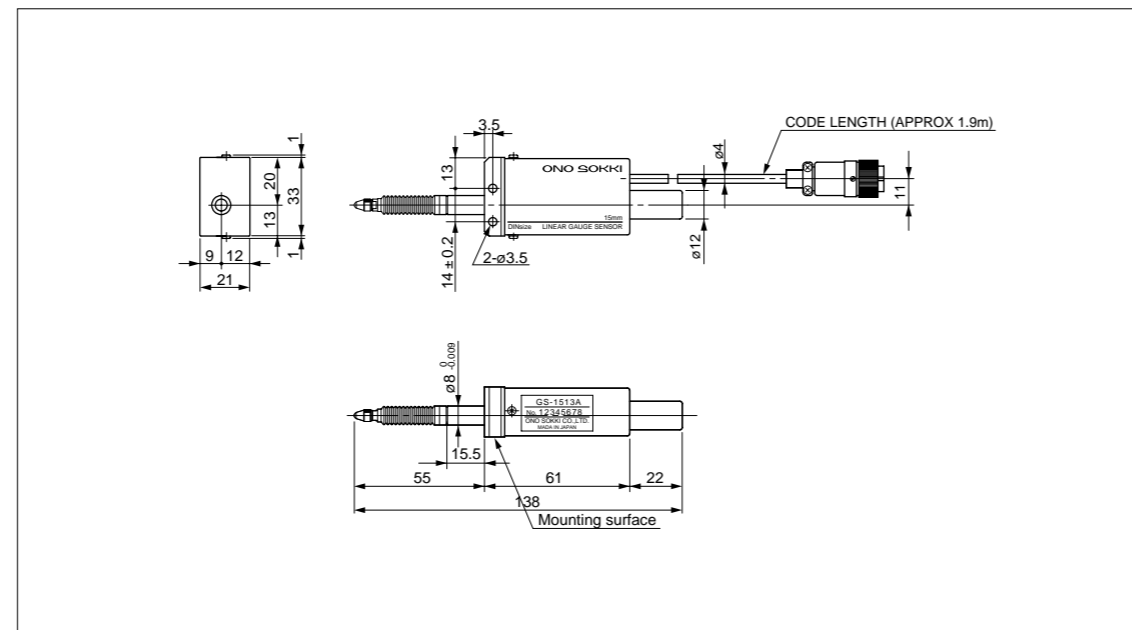

● GS-1530A/1630A Dimensional Outline Drawing

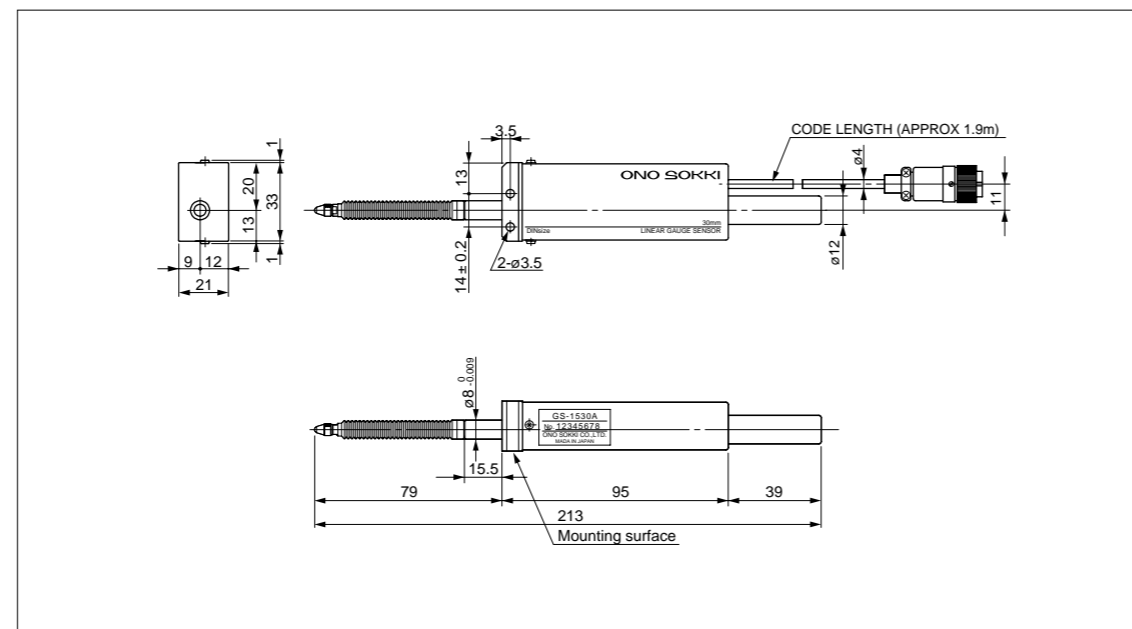

Troubleshooting

If you suspect a failure, check the following items. If the sensor does not operate normally after the troubleshooting, contact your sales representative or our sales office.

Symptom	Cause	Countermeasure/Checked Item
Spindle operates awkwardly.	Stem is too tight.	Do not tighten the stem portion with excessive force.
	Dust-proof rubber cover has degraded due to oil or chemicals.	The rubber cover has no anti-oil or anti-chemical performance. After replacing the dust-proof rubber cover with a new replacement, take proper measures to prevent contact with oil or chemicals.
Measured values are unstable.	Sensor mounting is unstable.	Firmly fix the gauge sensor.
	Probe installation section is loose.	Firmly install the probe.
	Electrical noise is generated.	Isolate the sensor cable as far as possible from the power cable or equipment which generates electrical interference including switching surge.
	When vibration, a shock, speed, etc. are excessive	Please do not add vibration and a shock to a gauge sensor as much as possible.

Specifications

● Mechanical specifications

Item	GS-1513A	GS-1530A	GS-1613A	GS-1630A
Measurement range (mm)	13	30	13	30
Resolution (μm)	10	10	1	1
Precision (μm)	3	3	2	3
Response speed (m/s)	1 (4) *2	1 (4) *2	0.3 (1.2) *2	0.3 (1.2) *2
Measurement force (N)	1.5	2.0	1.5	2.0

*2 It is available when our digital gauge counter is used.

The value, which is written at (), is maximum response speed when it is combined with our model DG-4140/4160.

● Electrical specifications

Item	GS-1513A	GS-1530A	GS-1613A	GS-1630A
Power supply	4.5 to 6.0 VDC			
Current consumption	50 mA or less (5 VDC)		100 mA or less (5 VDC)	
Signal output	2-phase square wave signal Phase difference: 90° ± 20° Output voltage Hi: 4.5V or higher / Lo: 0.4V or lower			
Output impedance	Approx. 140 Ω		Approx. 470 Ω	Approx. 440 Ω

● General specifications

Operating temperature range	0 °C to +40°C			
Storage temperature range	-10 °C to +55 °C (annual average humidity 75% or less / No condensation)			
Altitude	2000 m			
Cable length	Approx. 1.9 m			
Cable extension	Up to 30 m *3			
Mass	GS-1513A/1613A: Approx. 190 g / GS-1530A/1630A: Approx. 220 g (including cable)			
Accessory	Spacer: 1 piece, Instructor Manual (this document): 1 copy			
Protection class	IP64			
Option (separately available)	<ul style="list-style-type: none"> Air lifter: AA-6100 (13 mm) / AA-6101 (30 mm) Finger lift: AA-969 Gauge stand: ST-011/022/044B (AA-892 is required for ST-044B.) Spare dust-proof rubber cover: AA-4100 (13 mm) / AA-4101 (30 mm) 			
* Refer to the catalog for details.				

*3 It is set to 20m at the time of EMC conformity cable AA-803 use.

Confirming safety standards

The GS-1513A, GS-1530A and GS-1630A is designed and tested to comply with the following standards.

· CE Marking	EMC Directive	EN61326 : 1997, A1 : 1998, A2 : 2001 EN61000-6-4 : 2001 EN61000-6-2 : 2001
· FCC	Part 15B	class A satisfied

The GS-1613A is designed and tested to comply with the following standards.

· CE Marking	EMC Directive	EN61000-6-4 : 2001 EN61000-6-2 : 1999
· FCC	Part 18	class A satisfied

This equipment has been tested and found to comply with the limits for a Class A digital device, pursuant to Part 15 of the FCC Rules. These limits are designed to provide reasonable protection against harmful interference when the equipment is operated in a commercial environment. This equipment generates, uses, and can radiate radio frequency energy and, if not installed and used in accordance with the instruction manual, may cause harmful interference to radio communications. Operation of this equipment in a residential area is likely to cause harmful interference in which case the user will be required to correct the interference at his own expense.

This Class A digital apparatus complies with Canadian ICES-003.

Cet appareil numérique de la classe A est conforme a la norme NMB-003 du Canada.

- This document may not be reproduced, in whole or part, in any form or by any means without the prior written permission of the publisher.
- The contents of this document are subject to change without notice.
- This document has been produced based on a series of strict verifications and inspections. Should a failure occur nonetheless, please inform our sales representative or sales office.
- Ono Sokki shall have no liability for any effect resulting from any operation, whether or not the effect is attributable to a defect in the documentation.